

Well

All dimensions may not exceed perpendicular tolerance of ± 2 cm

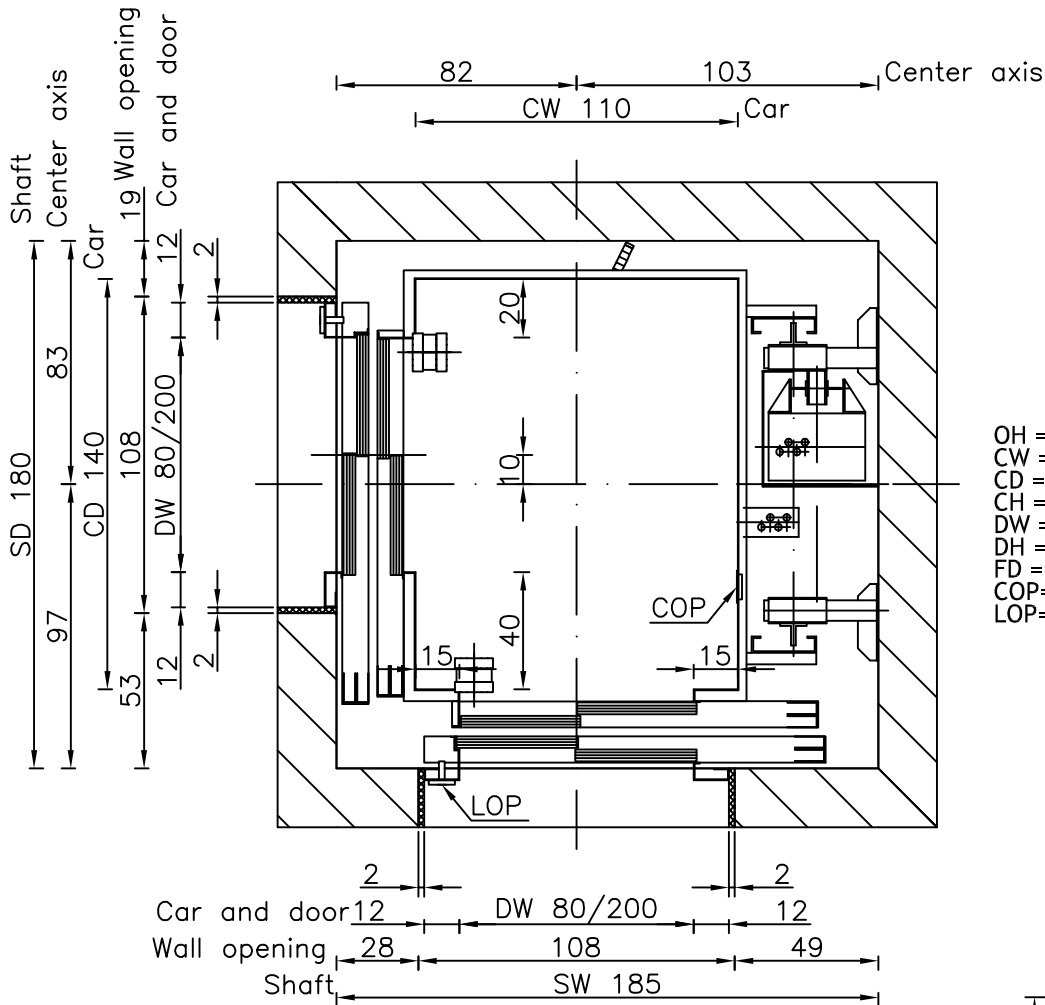

- OH = Overhead
- CW = Car width
- CD = Car depth
- CH = Car height
- DW = Door width
- DH = Door height
- FD = Floor distance
- COP = Car Operating Panel
- LOP = Landing Operating Panel

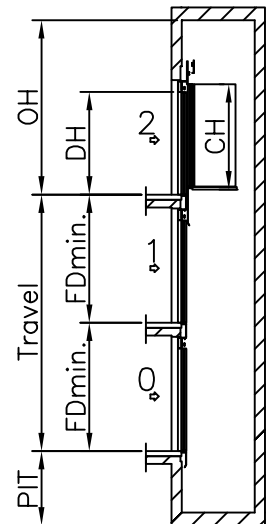
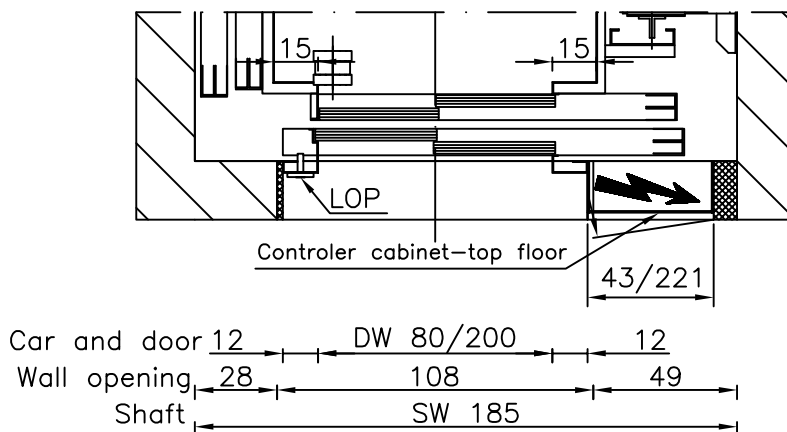

Speed: 1 m/s	
PIT: 120 cm	
OH: 360 cm	
CW: 110 cm	DW: 80 cm
CD: 140 cm	DH: 200 cm
CH: 210 cm	
FDmin.: 250 (CH+50 cm)	

Dimensions in cm.

TYPICAL POWER REQUIREMENTS	
Motor Power (k.W.)	7,3 kW
Running current	17,5 A
Starting current	25 A

Type:	GEARED 630 kg TR8-TR8		Drawn By:	Tomi Irgotič	
	ELECTRIC		Date:		
			Revision:	00	Page:
					106