

Well

All dimensions may not exceed perpendicular tolerance of ± 2 cm

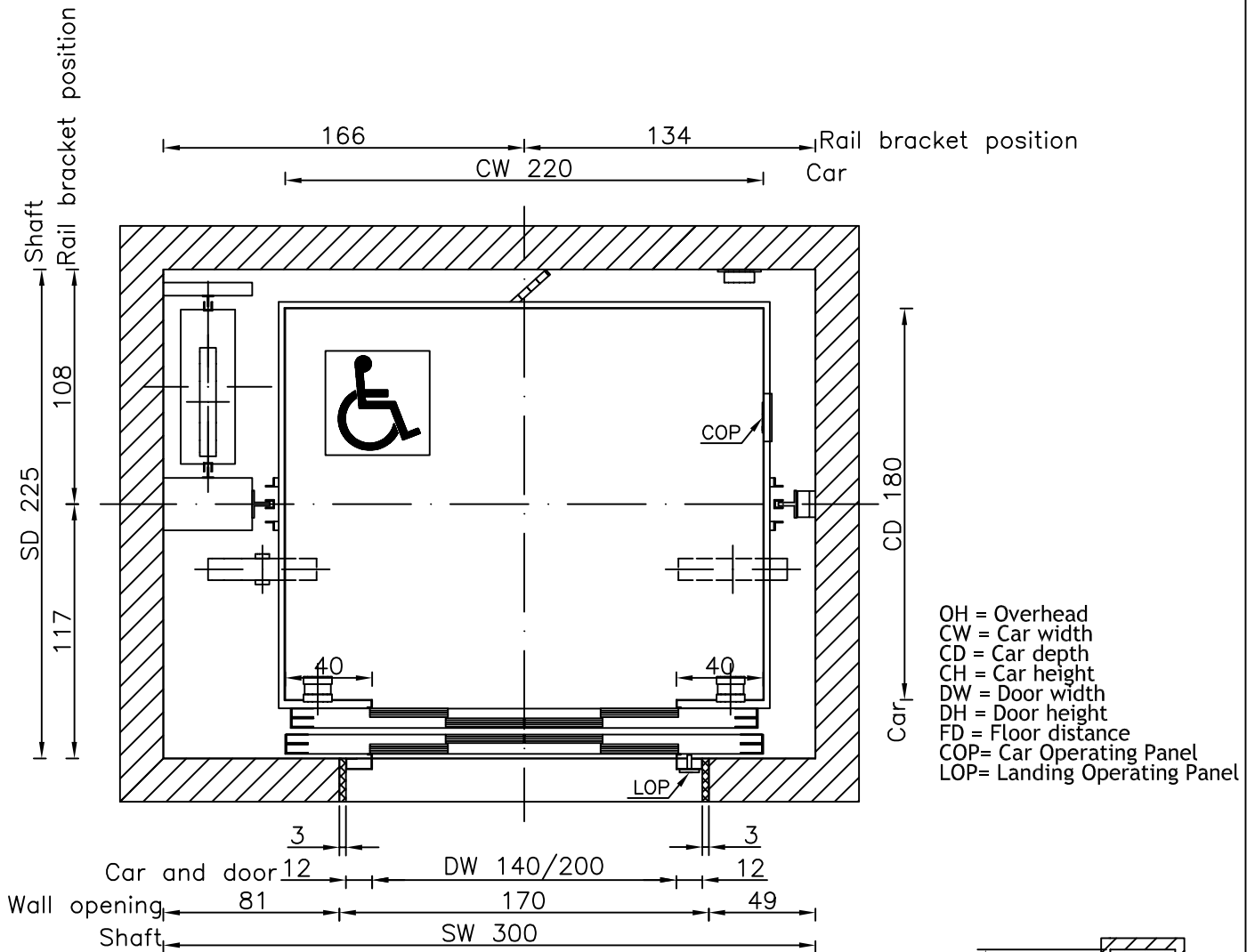

- OH = Overhead
- CW = Car width
- CD = Car depth
- CH = Car height
- DW = Door width
- DH = Door height
- FD = Floor distance
- COP= Car Operating Panel
- LOP= Landing Operating Panel

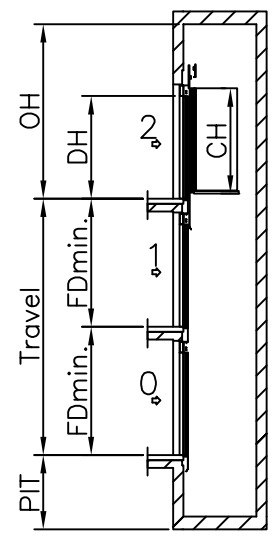
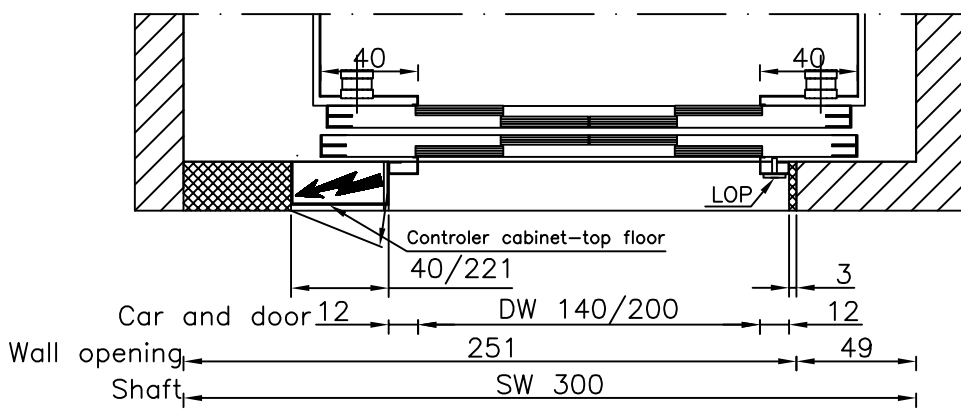

Speed: 1 m/s	PIT: 180 cm
OH: 450 cm	
CW: 220 cm	DW: 140 cm
CD: 180 cm	DH: 200 cm
CH: 200 cm	
FDmin.: 260 (CH+50 cm)	

Dimensions in cm.

TYPICAL POWER REQUIREMENTS	
Motor Power (k.W.)	19 kW
Running current	41 A
Starting current	50 A

Type:	MRL 2000 kg 4TC14		Drawn By:	Tomi Irgolič
	ELECTRIC		Date:	05.01.2009
		A4	Revision:	Page:
		1:30	00	143

