

Trolleylift Builder's Work Schedule and Electrical Details

Stage 1

Site: [REDACTED]

Job No: [REDACTED]

Model: 250C

Date: [REDACTED]

The following work must be completed before installation can commence:

Building

- 1 Provide a trimmed floor aperture (inside lift shaft) through the floor(s) which the TROLLEYLIFT is to travel through to dimensions 1320 mm x 1320 mm (tolerance +25 mm -0 mm).
- 2 Provide a pit at the bottom floor served 1320 mm wide x 1320 mm deep (tolerance +25 mm -0mm) x 350mm high. Ensure the base (pit floor) of the lift shaft is **flat, dry, fully waterproof, and capable of withstanding a downward deadload of [REDACTED] tonnes** distributed over four legs of the lift structure.

See Data Sheet
DS0019 & DS0020

IMPORTANT: IN THE EVENT OF THERE BEING AN ACCESSIBLE VOID BENEATH THE BOTTOM OF THE LIFT SHAFT, SUITABLE PRECAUTIONS MUST BE TAKEN TO AVOID POSSIBLE INJURY TO PERSON. PLEASE CONTACT US TO DISCUSS THE MATTER FURTHER.

- 3 Form recess at each entrance nosing 70 mm wide x 40 mm deep x full width of shaft. If a recess cannot be provided, the lift will serve at 35 mm above finished floor level (ffl) and the builder will have to provide a suitable ramp. On through car arrangements (entrances on opposite sides), a recess is not required - builder to fill in around bottom tracks after installation.
- 4 Provide adequate dry storage, adjacent to the lift shaft, for our materials when delivered to site.

- 5 Ensure that there is safe and uninterrupted access to the lift shaft, eg **stairs and boarded floors**, to each level of the building that the lift is to serve to enable us to carry and distribute the heavy equipment in safety.

NOTE: If there is no safe means of access, as outlined above, we shall be unable to install the lift equipment and may need to withdraw our labour from site. Should this situation arise, we would raise a charge, in line with our quotation, and would not return to site until safe to do so.

- 6 **IMPORTANT:** Do not build any entrance fronts at this stage but leave clear from floor to ceiling until after the lift has been fitted. **PLEASE NOTE** that if any entrance fronts are constructed at this stage, we will not be able to install the lift until they have been removed.

ELECTRICAL PROVISION

required to enable first fix to take place

NB A lift installation is considered to be a self-contained piece of equipment and as such is not required to conform in all respects with the 16th Edition of the Institute of Electrical Engineers Regulations for Electrical Installations

- 7 Provide a permanent 415 volt - 3 phase - 50 Hertz power supply with good earth, terminating in a 15 amp triple pole fused and switched isolator, which should be capable of being locked in the **off** position. This is to be positioned adjacent to the lift shaft (**not** inside the shaft and approximately 2 metres (6' 6") above finished floor level at the top floor served - **motor running current 4.0 amps, starting current 9.0 amps, 0.66 kW, 0.9 hp.**

**If the permanent isolator is not available at this stage and we are unable to route our mains cable prior to the cladding (enclosure) work, builder must arrange to route our mains cable to the isolator position in order to avoid possible problems with final finishes at commission stage.*

In addition, a dedicated 240V – 1-phase – 10 amp supply, terminated in a switched 13 amp socket **MUST BE PROVIDED INSIDE** what will be the lift motor compartment at the top of the lift shaft. **This is to provide power for a light fitting, which we will supply.**

- 8 Provide a 110 volt (or 240 volt) power supply for tools, adjacent to the lift, for the duration of the installation.
- 9 Provide adequate lighting in the lift shaft for the duration of the installation.

Trolleylift Builder's Work Schedule Stage 2 (CONCERTINA LANDING DOORS)

Job No: ████████

Date: ████████

After the Trolleylift has been installed the builder is to carry out the following:

It is **imperative** that the Trolleylift is enclosed thoroughly and property to comply with the current safety requirements of the Health & Safety at Work Act, together with the Supply of Machinery (Safety) Regulations 1992.

- 1 Complete the enclosure (lift shaft) around the lift structure and make good around our door frames, excluding any gaps which could become finger traps, taking care not to obscure the door release keyhole at the bottom of the push button panel. The lift shaft need not be load-bearing and only serves to protect against moving parts; it may also have to comply with the Local Authority Fire Regulations and we recommend you check their requirements.

It is typical to provide a fire-resistant enclosure by using battens or spacers fixed to our structure and clad with Supalux; care must be taken, however, to avoid damage to our cables when fixing any materials to our structure. Alternatively, a breeze-block/brick shaft can be used providing the lift equipment is protected from damp, dust, rubble, etc during the construction of the shaft walls.

- 2 Make good the floor up to and around gate bottom tracks, and ensure the track is kept clean and free from dust etc.
- 3 Provide two x **hinged and lockable** access door(s) size **700mm** wide x **700mm** high at the top of the lift shaft for maintenance purposes, as shown on our general arrangement drawing. ***If this arrangement cannot be achieved, please contact us to discuss.*** Please note that the locking of the access doors must be by means of a simple mortise (Union ref 2177) or cylinder lock (Yale ref P84) and that tower/barrel bolts, budget locks or mirror screws are **not** acceptable, as they do not comply with current regulations.

NOTE: It is now a statutory obligation to provide a safe means of access and lighting to the lift motor compartment. Thus, we suggest that a safe step ladder or ladder should always be available for safe access to the motor compartment.

NOTE: Permanent notices reading DANGER - LIFT MACHINERY, UNAUTHORISED ACCESS PROHIBITED - DOOR TO BE KEPT LOCKED must be fitted on the outside of the motor compartment doors to comply with current safety regulations. Our installer will fit these notices when he returns to test and commission the lift.

- 4 Clean down the interior of the lift shaft and lift equipment thoroughly to remove all builder's dust, rubble and waste matter. We will not accept liability for any damage caused through negligence or non-compliance with these requirements.
- 5 Paint landing door frames in colour to suit client's choice (the frames are supplied primed).
- 6 Paint each shutter leaf gate in colour to suit client's choice, if required (the gates are supplied galvanised).

NOTE: If any of the above items 1 to 4 have not been completed, we will be unable to test the lift or affix the CE Mark, and an additional return visit charge will then be raised before we can make new arrangements to return.

--

DO NOT SCALE

IF IN DOUBT - ASK

UNLESS OTHERWISE ADVISED, WE WILL INSTALL THE LIFT TO THE CONFIGURATION AND DIMS SHOWN ON THIS DRAWING

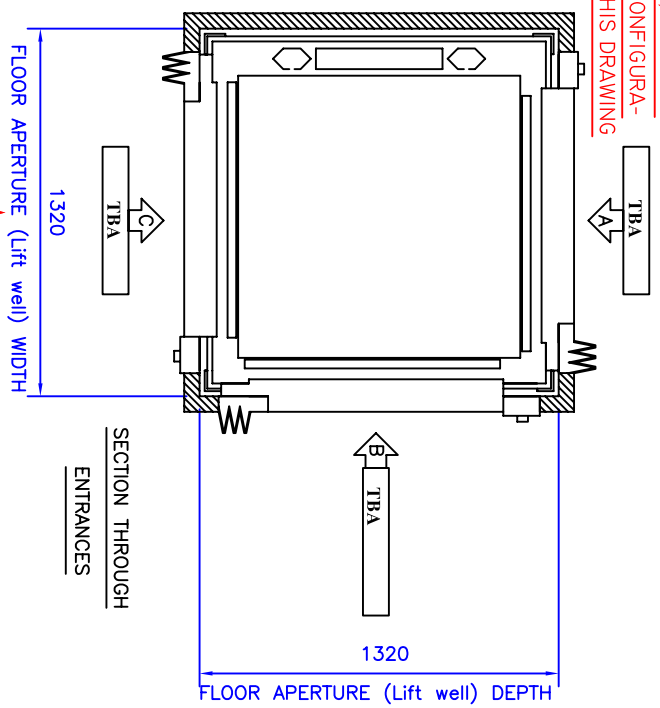
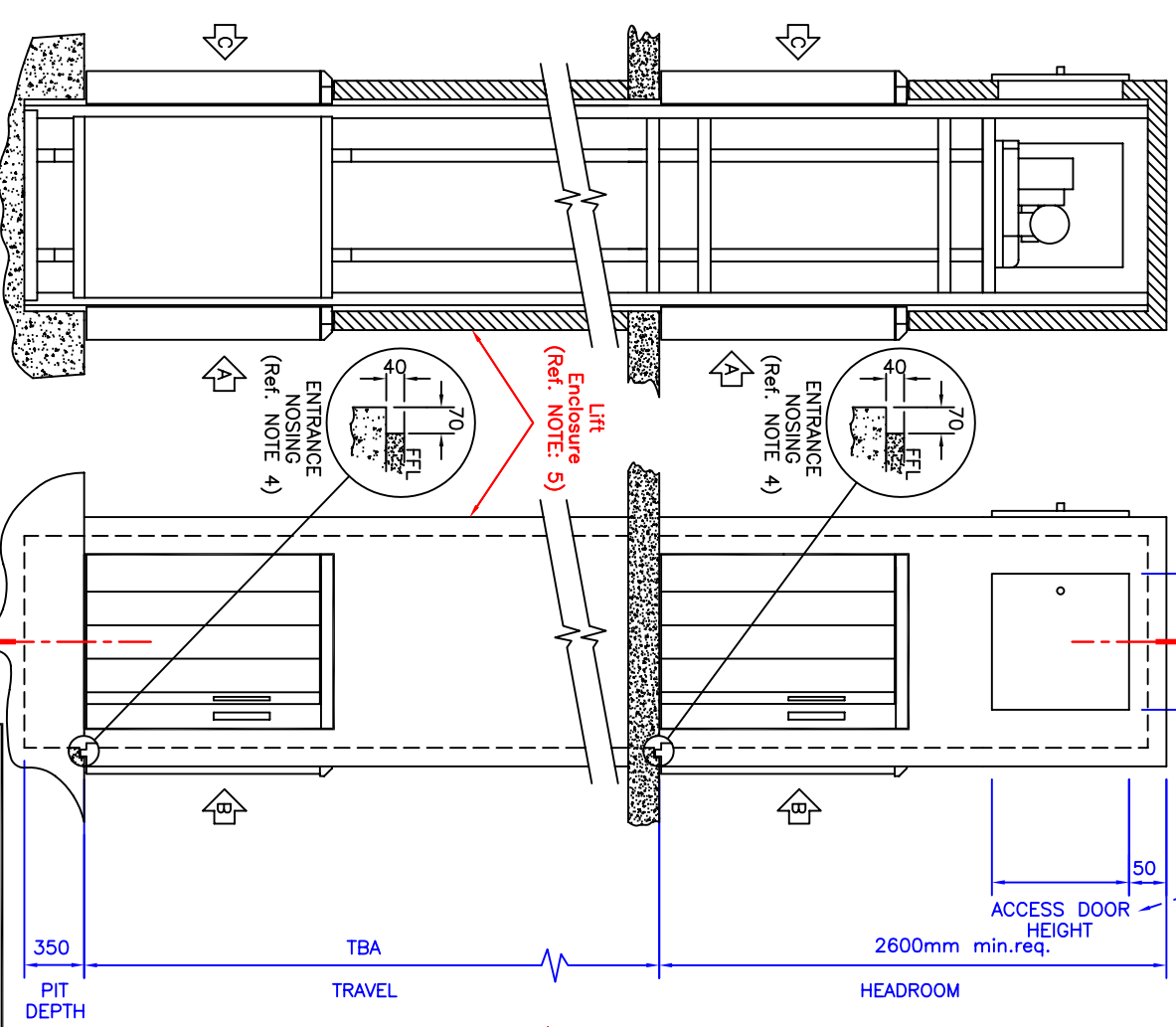

NOTES

1. Please read this drawing in conjunction with our builder's Work Schedule Stages 1 & 2.
 2. Builder to provide trimmed floor aperture (lift well) to minimum dimensions 1320mm wide x 1320mm deep (tolerance +25mm, -0mm).
 3. Provide a pit to minimum dimensions 1320mm (lift well) width x 1320mm (lift well) depth (tolerance +25mm, -0mm) x 350 mm (pit depth), where this is not practicable, a suitable ramp/s to be provided to a height to match the pit depth.
 4. Builder to form recess at each entrance nosing 70mm wide x 40mm deep x full width of well (not required with through car arrangement, e.g. A and C entrances).
 5. Builder to provide enclosure and entrance liners. **DO NOT BUILD UNTIL AFTER LIFT INSTALLATION**
 6. Builder to provide 2 hinged and lockable access doors, as shown, each 700mm wide x 700mm high.
 7. Builder to provide a 13amp socket within the motor room area.
 8. Builder to provide motor room access ladder.
- N.B. If items 5,6,7 and 8 are not complete when we return to test, commission and affix a CE Mark to the lift, then an additional return visit charge will be raised in line with our quotation.

TYPICAL SECTION (X-X)
ALL DIMS IN MMS

TYPICAL FRONT ELEVATION IN DIRECTION OF ARROW Z

SITE ADDRESS:
TBA

Trolleylift
250C
SERVICE LIFTS

DRAWN BY: C.H DATE: 2-9-05

DRAWING NUMBER:
FOR INFO. ONLY