

Well

All dimensions may not exceed perpendicular tolerance of ± 2 cm

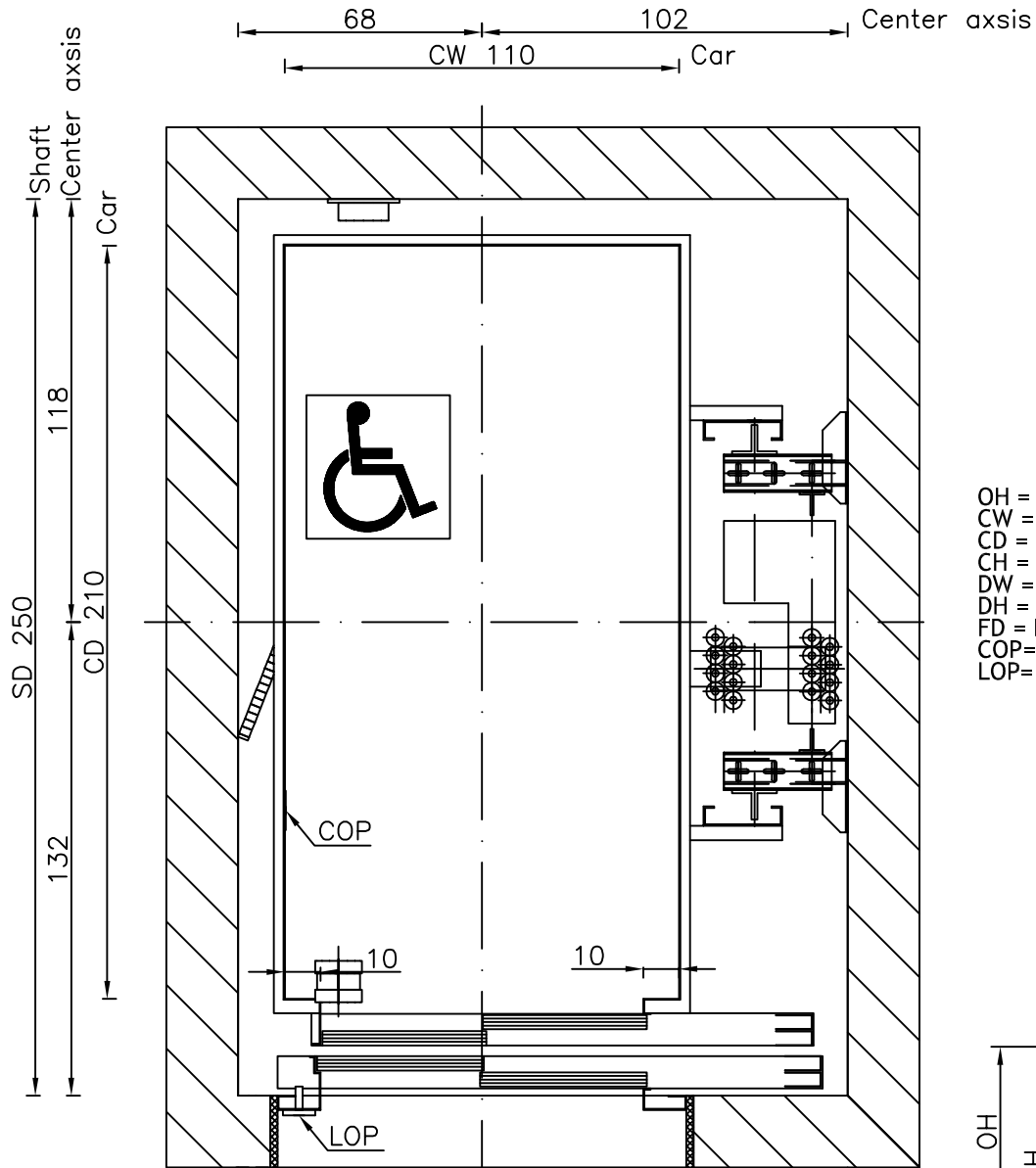

- OH = Overhead
- CW = Car width
- CD = Car depth
- CH = Car height
- DW = Door width
- DH = Door height
- FD = Floor distance
- COP= Car Operating Panel
- LOP= Landing Operating Panel

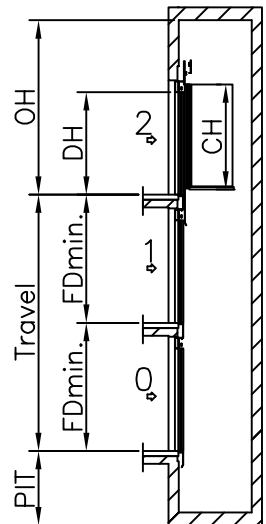
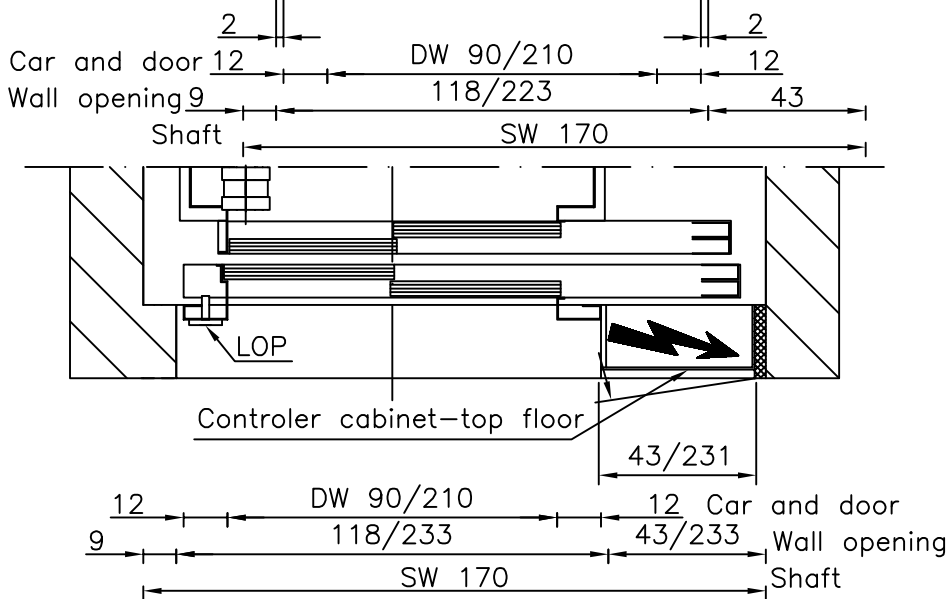

Speed: 1 m/s	
PIT: 140 cm	
OH: 370 cm	
CW: 110 cm	DW: 90 cm
CD: 210 cm	DH: 210 cm
CH: 220 cm	
FDmin.: 260 (CH+50 cm)	

TYPICAL POWER REQUIREMENTS	
Motor Power (k.W.)	6,1 kW
Running current	21,8 A
Starting current	28,5 A
Overload current	37 A

Type: **Gearless MRL 1000 kg TR9**

ELECTRIC	A4	Revision: 00	 Page: 28
	1:20		

Dimensions in cm.