

Well

All dimensions may not exceed perpendicular tolerance of ± 2 cm

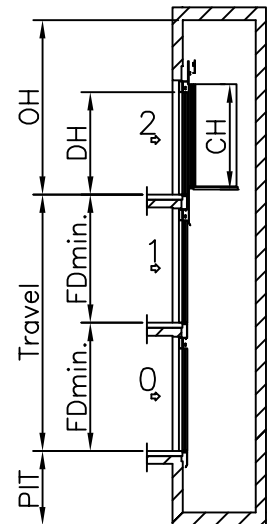
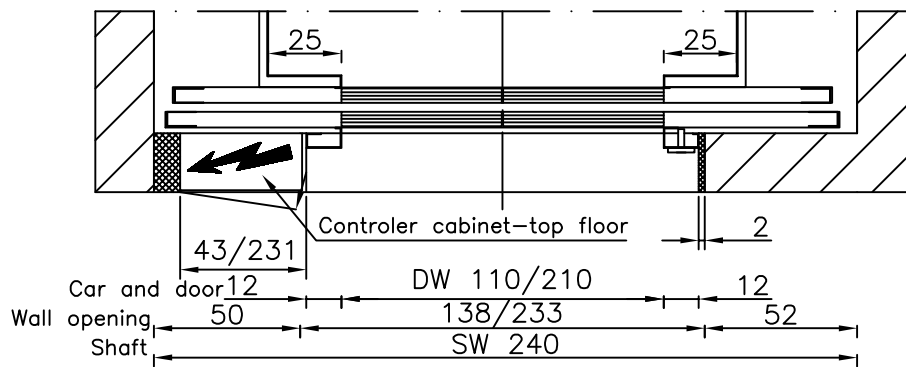
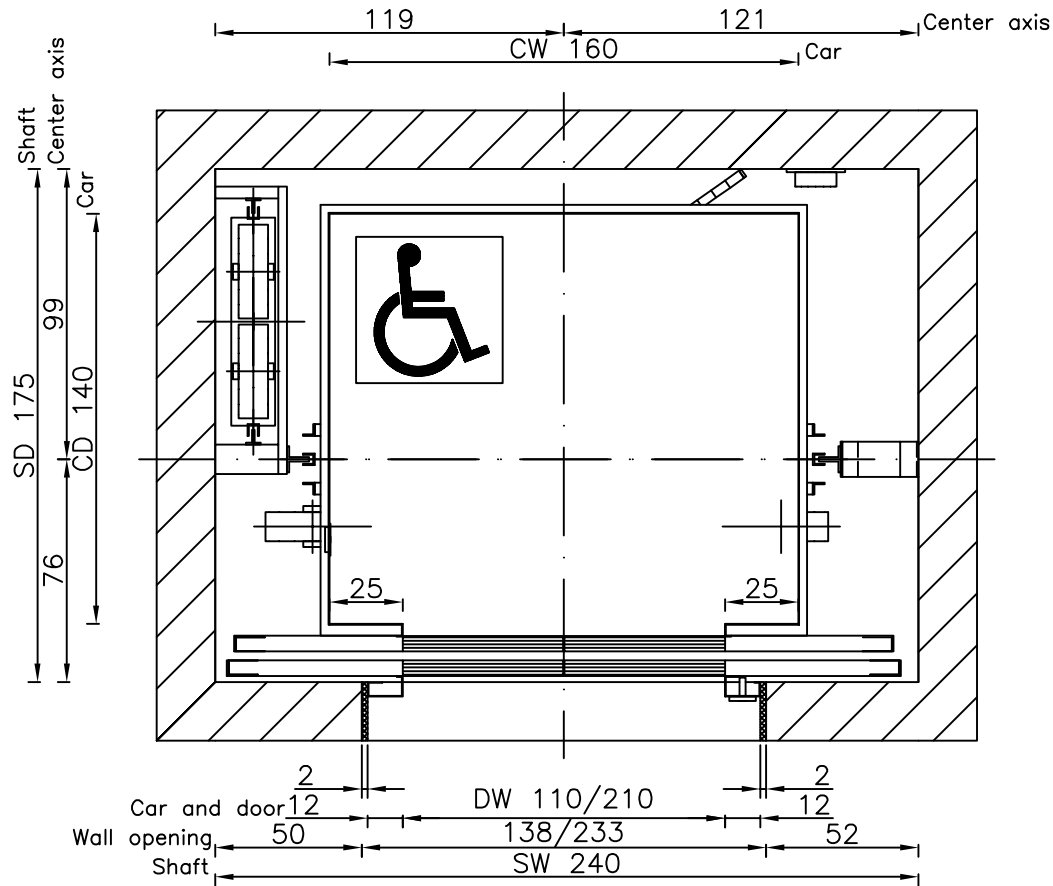

OH = Overhead
 CW = Car width
 CD = Car depth
 CH = Car height
 DW = Door width
 DH = Door height
 FD = Floor distance
 COP= Car Operating Panel
 LOP= Landing Operating Panel

Speed: 1 m/s	
PIT: 140 cm	
OH: 370 cm	
CW: 160 cm	DW: 90 cm
CD: 140 cm	DH: 210 cm
CH: 220 cm	
FDmin.: 260 (CH+50 cm)	

TYPICAL POWER REQUIREMENTS	
Motor Power (k.W.)	9,2 kW
Running current	21,5 A
Starting current	25,8 A
Overload current	33,5 A

Type:	GEARED MRL 1000 kg CT11		Drawn By:	SEC
	ELECTRIC		Tomi Irgotič	
	A4		Date:	
	1:20		Revision:	Page:
			01	30

Dimensions in cm.