

Well

All dimensions may not exceed perpendicular tolerance of ± 2 cm

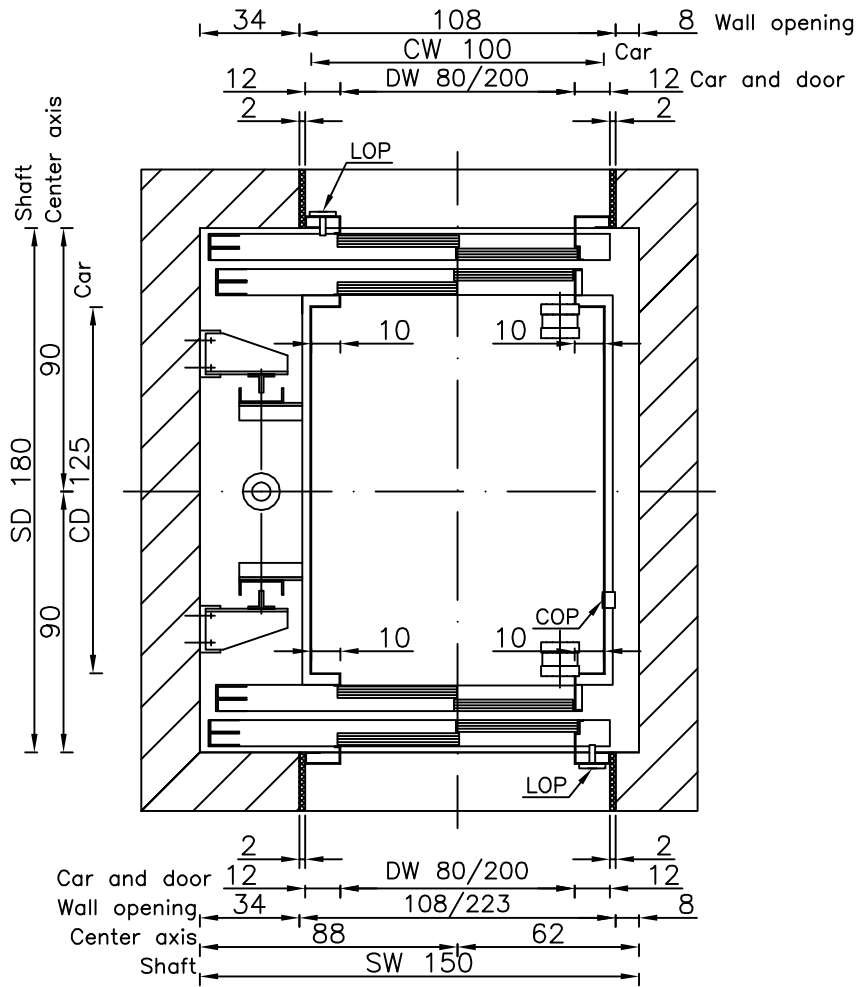

OH = Overhead
 CW = Car width
 CD = Car depth
 CH = Car height
 DW = Door width
 DH = Door height
 FD = Floor distance
 COP = Car Operating Panel
 LOP = Landing Operating Panel

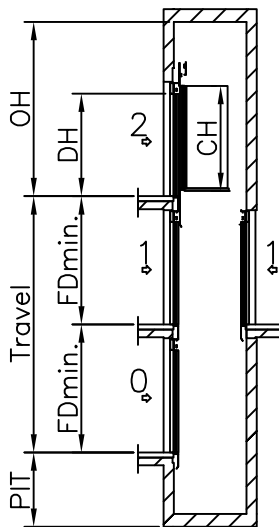

Speed: 0,6 m/s
 PIT: 120 cm
 OH: 320 cm

CW: 100 cm DW: 80 cm
 CD: 125 cm DH: 200 cm
 CH: 210 cm
 FDmin.: 250 (CH+50 cm)

HYDRAULIC MOTOR-ROOMLESS OPTIONS:

The space saving design cleverly houses the motor in a cabinet that can either be located on or recessed into an adjacent wall.

If space is limited beside the shaft the cabinet can be located up to 10 meters away.

Max. Travel height 320 cm.

HYDRAULIC MASCHINE ROOM REQUIREMENTS:

Maschine room min. dimension: 150 x 165

TYPICAL POWER REQUIREMENTS	
Motor Power (k.W.)	6 kW
Running current	13 A
Starting current	17 A
Overload current	22.1 A

Dimensions in cm.

Type:	DIRECT 480 kg TL8-TR8	Drawn By: Tomi Irgolič	
		Date: 30.01.2007	
	HYDRAULIC	Revision: A4	Page: 31
		1:25	00