

Well

All dimensions may not exceed perpendicular tolerance of ± 2 cm

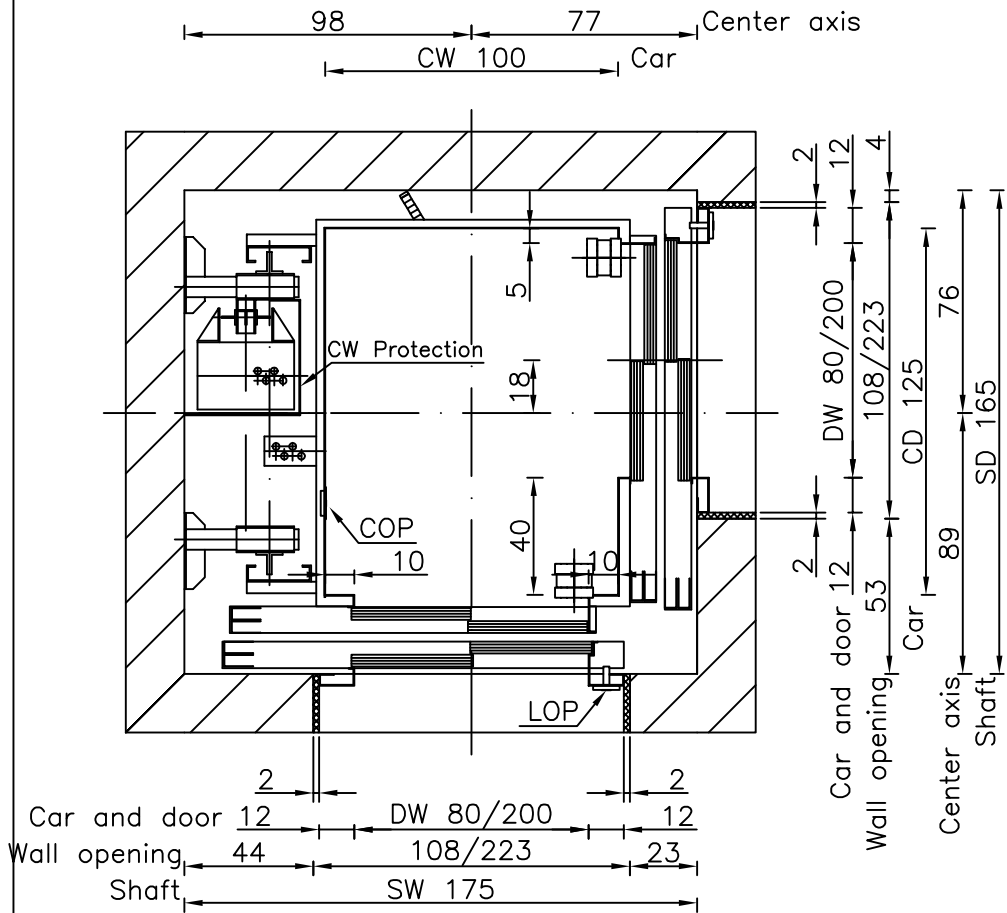

- OH = Overhead
- CW = Car width
- CD = Car depth
- CH = Car height
- DW = Door width
- DH = Door height
- FD = Floor distance
- COP = Car Operating Panel
- LOP = Landing Operating Panel

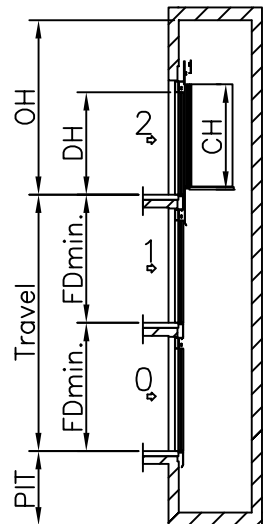
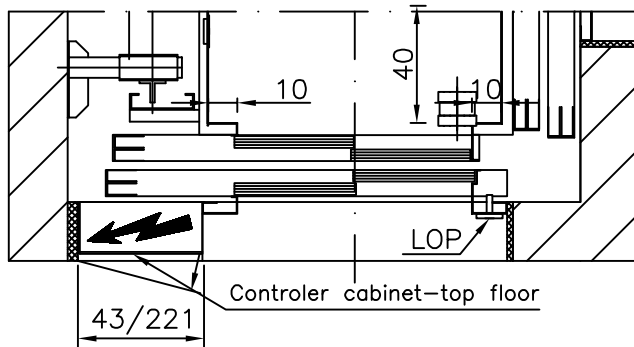

| | |
|------------------------|------------|
| Speed: 1 m/s | |
| PIT: 120 cm | |
| OH: 360 cm | |
| CW: 100 cm | DW: 80 cm |
| CD: 125 cm | DH: 200 cm |
| CH: 210 cm | |
| FDmin.: 250 (CH+50 cm) | |

| TYPICAL POWER REQUIREMENTS | |
|----------------------------|-------|
| Motor Power (k.W.) | 7,3kW |
| Running current | 17,5A |
| Starting current | 25 A |
| Overload current | 32,5A |

Dimensions in cm.

| | | | | | |
|-------|---------------------------|------|-----------|--------------|-------|
| Type: | GEARED MRL 480 kg TL8-TL8 | | Drawn By: | Tomi Irgotič | SEC |
| | | | Date: | | |
| | ELECTRIC | A4 | Revision: | 00 | Page: |
| | | 1:25 | | | 44 |