

# Well

All dimensions may not exceed perpendicular tolerance of  $\pm 2$  cm

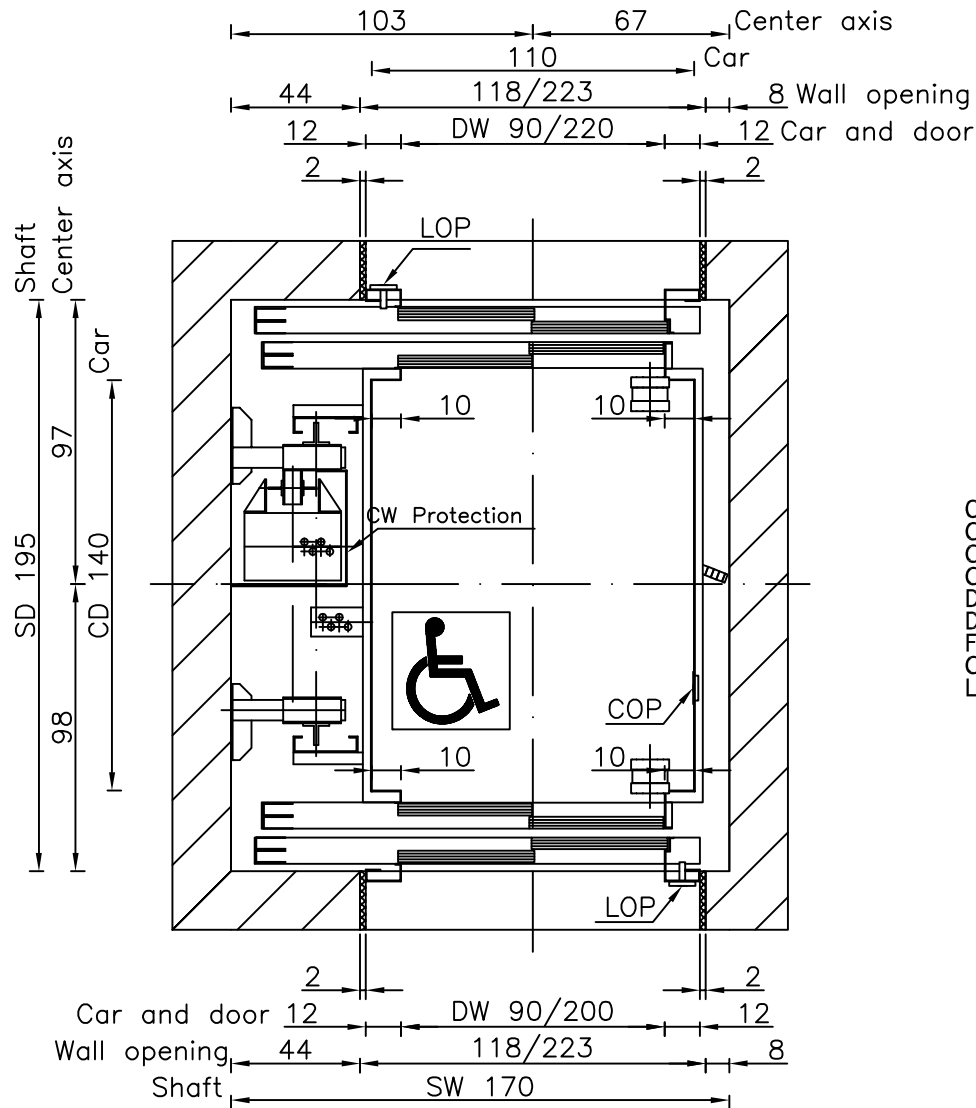

- OH = Overhead
- CW = Car width
- CD = Car depth
- CH = Car height
- DW = Door width
- DH = Door height
- FD = Floor distance
- COP= Car Operating Panel
- LOP= Landing Operating Panel

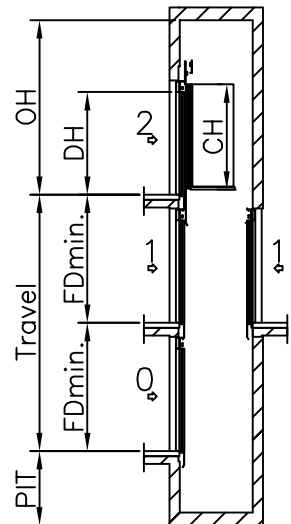
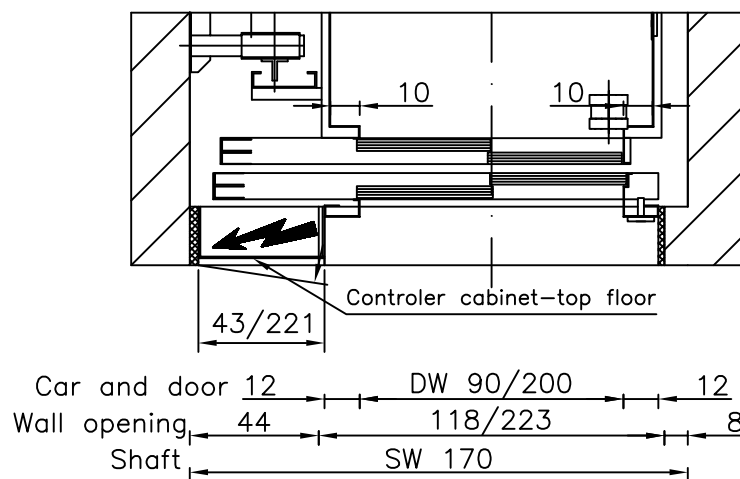

Speed: 1 m/s	
PIT: 120 cm	
OH: 360 cm	
CW: 110 cm	DW: 90 cm
CD: 140 cm	DH: 200 cm
CH: 210 cm	
FDmin.: 250 (CH+50 cm)	

TYPICAL POWER REQUIREMENTS	
Motor Power (k.W.)	7,3 kW
Running current	17,5 A
Starting current	25 A
Overload current	32,5 A

Dimensions in cm.

Type: <b>GEARED 630 kg TL9-TR9</b>		Drawn By: Tomi Irgotič	
		Date: 19.10.2006	
<b>ELECTRIC</b>	<b>A4</b>	Revision:	Page:
	<b>1:25</b>	<b>00</b>	<b>46</b>