

Well

All dimensions may not exceed perpendicular tolerance of ± 2 cm

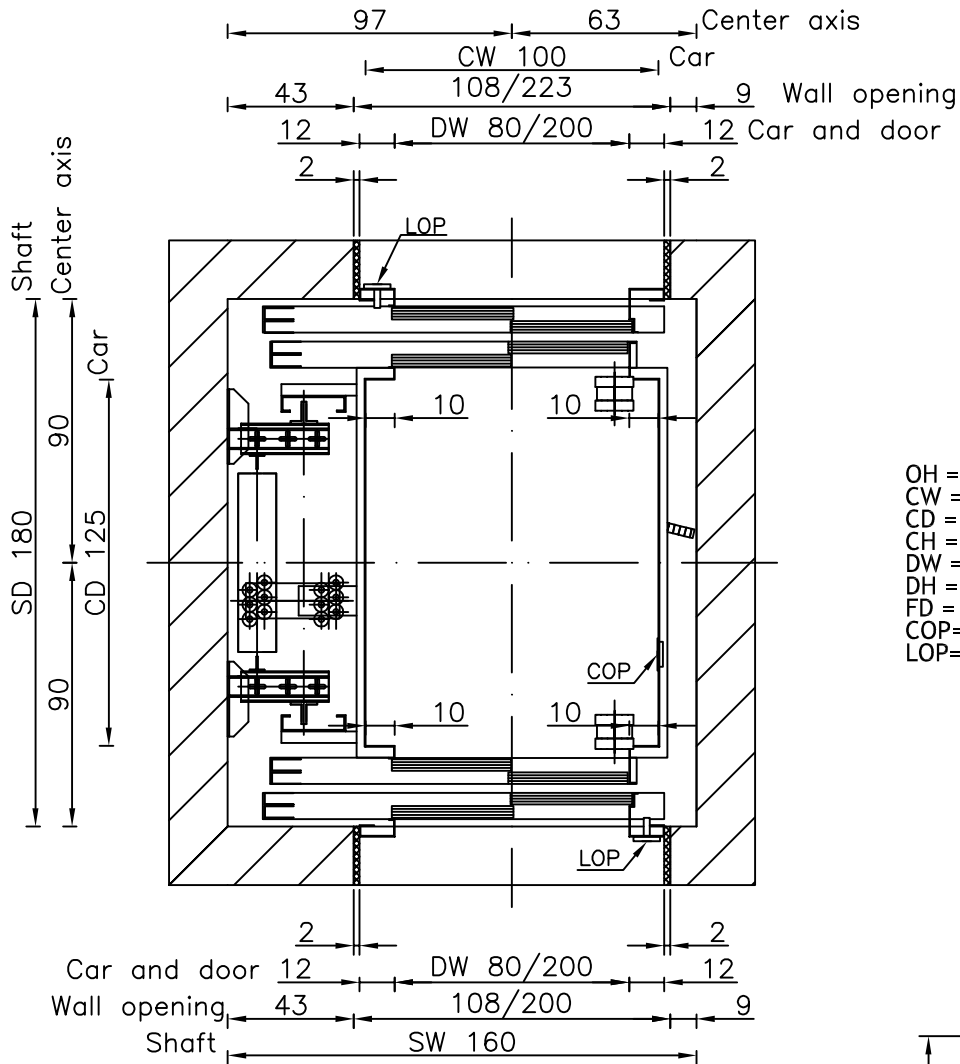

OH = Overhead
 CW = Car width
 CD = Car depth
 CH = Car height
 DW = Door width
 DH = Door height
 FD = Floor distance
 COP = Car Operating Panel
 LOP = Landing Operating Panel

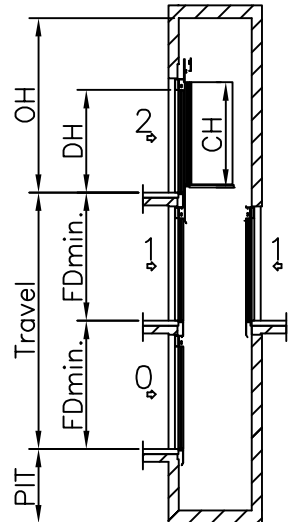
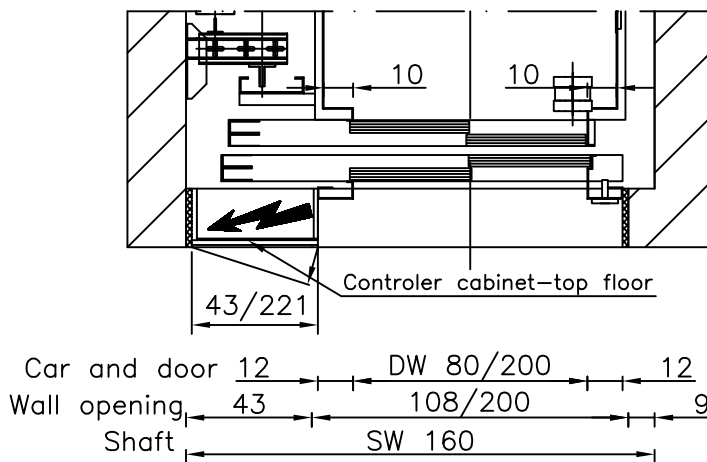

Speed: 1 m/s	
PIT: 120 cm	
OH: 360 cm	
CW: 100 cm	DW: 80 cm
CD: 125 cm	DH: 200 cm
CH: 210 cm	
FDmin.: 250 (CH+50 cm)	

Dimensions in cm.

TYPICAL POWER REQUIREMENTS	
Motor Power (k.W.)	2,8kW
Running current	10,8A
Starting current	16 A
Overload current	20,8A

Type: Gearless MRL 480 kg TL8-TR8

ELECTRIC

Drawn By: Tomi Irgotič	Revision: 00	Page: 52
Date: 05.02.2007		
A4		
1:25		