

Well

All dimensions may not exceed perpendicular tolerance of ± 2 cm

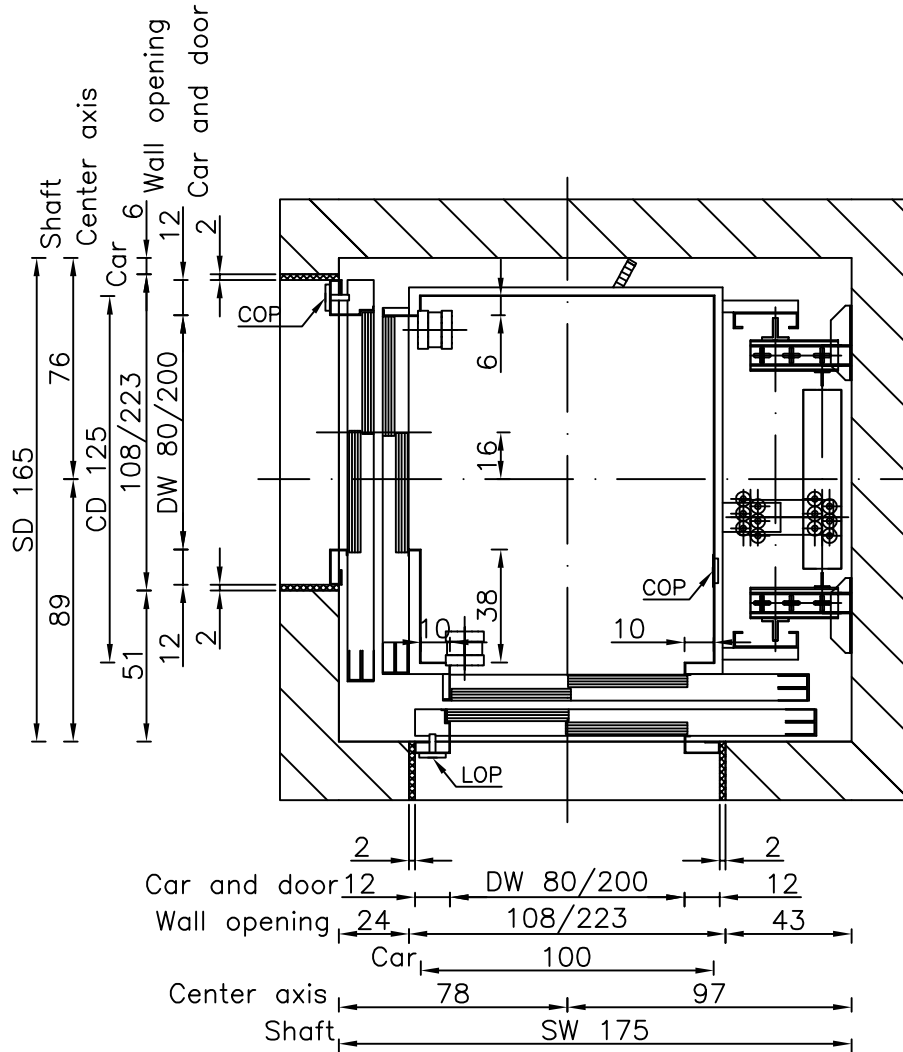

OH = Overhead
 CW = Car width
 CD = Car depth
 CH = Car height
 DW = Door width
 DH = Door height
 FD = Floor distance
 COP = Car Operating Panel
 LOP = Landing Operating Panel

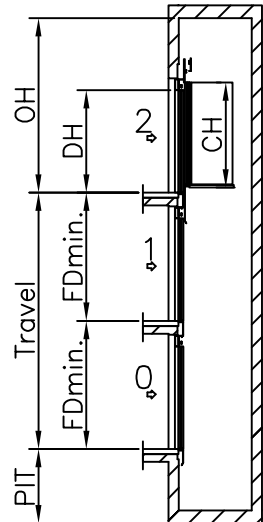
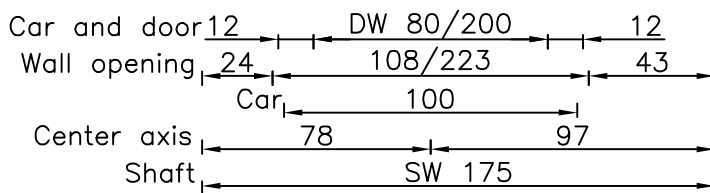
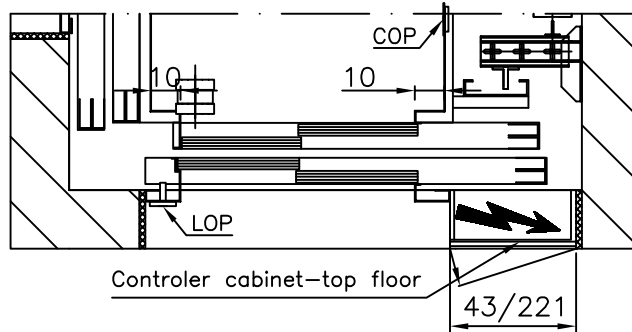

Speed: 1 m/s	
PIT: 120 cm	
OH: 360 cm	
CW: 100 cm	DW: 80 cm
CD: 125 cm	DH: 200 cm
CH: 210 cm	
FDmin.: 250 (CH+50 cm)	

TYPICAL POWER REQUIREMENTS	
Motor Power (k.W.)	2,8kW
Running current	10,8A
Starting current	16 A
Overload current	20,8A

Type: Gearless MRL 480 kg TR8-TR8

Drawn By:
Tomi Irgotič
Date:
05.02.2007



ELECTRIC

A4
1:25

Revision:
00

Page:
54

Dimensions in cm.