

Well

All dimensions may not exceed perpendicular tolerance of ± 2 cm

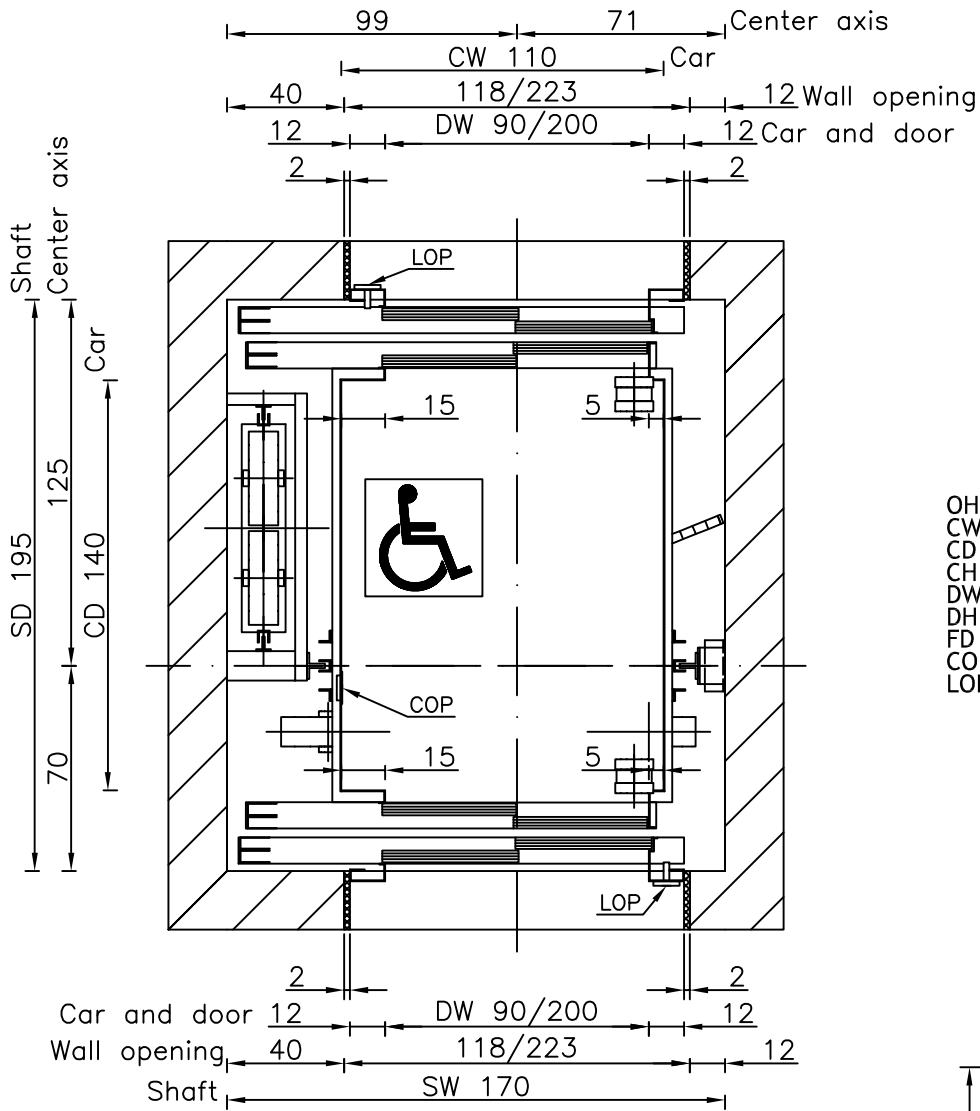

OH = Overhead
 CW = Car width
 CD = Car depth
 CH = Car height
 DW = Door width
 DH = Door height
 FD = Floor distance
 COP = Car Operating Panel
 LOP = Landing Operating Panel

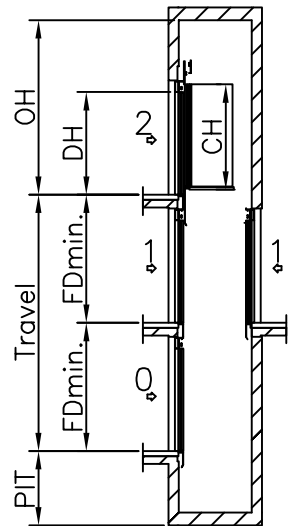
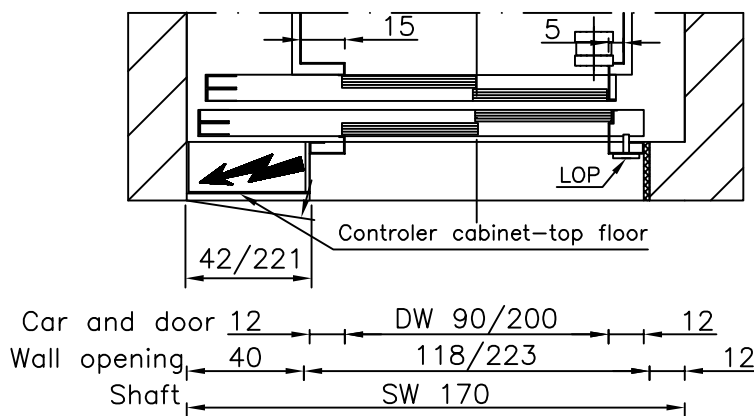

Speed: 1 m/s	PIT: 120 cm
OH: 360 cm	
CW: 110 cm	DW: 80 cm
CD: 140 cm	DH: 200 cm
CH: 210 cm	
FDmin.: 250 (CH+50 cm)	

TYPICAL POWER REQUIREMENTS	
Motor Power (k.W.)	3,8 kW
Running current	12,5 A
Starting current	18 A
Overload current	23,4 A

Dimensions in cm.

Type:	Gearless MRL 2:1 630 kg TL9-TR9		Drawn By: Tomi Irgolič	
			Date: 05.02.2007	
	ELECTRIC	A4 1:25	Revision: 00	Page: 60