

Well

All dimensions may not exceed perpendicular tolerance of ± 2 cm

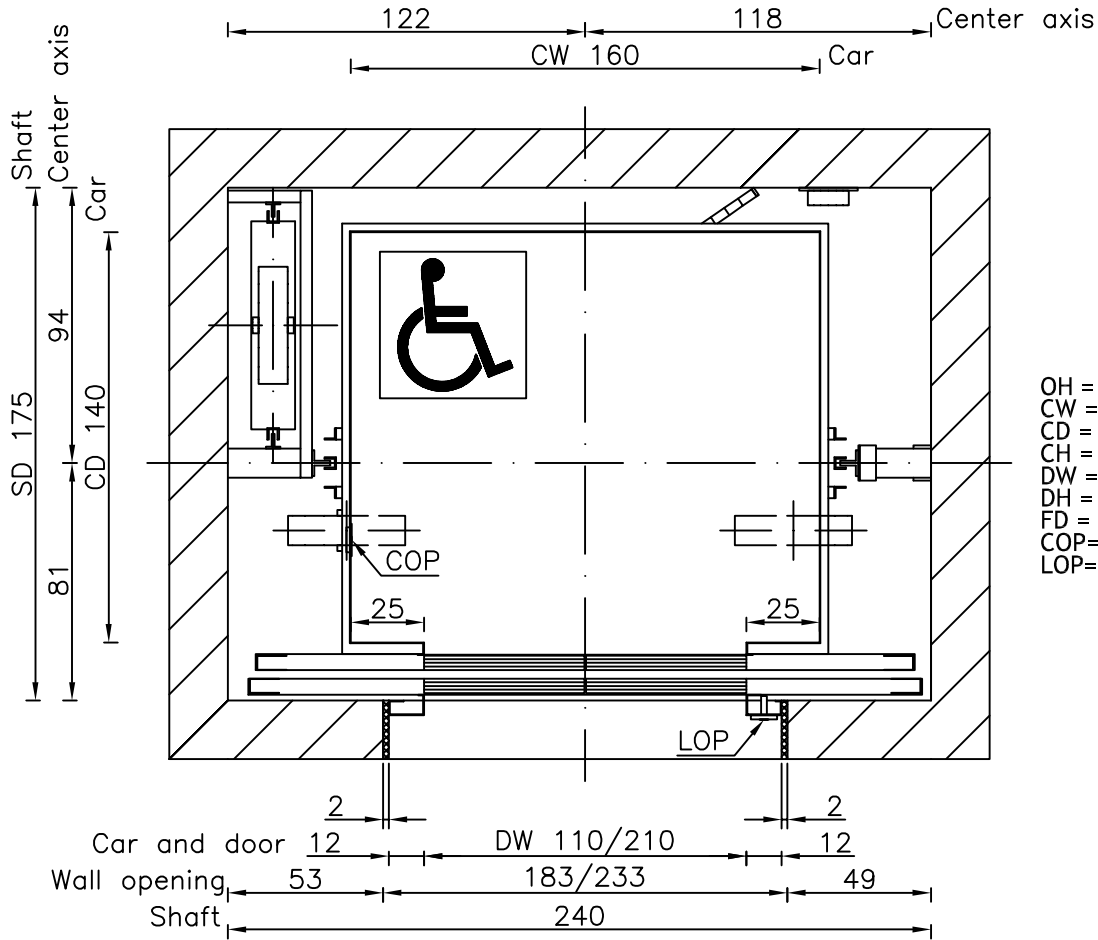

OH = Overhead
 CW = Car width
 CD = Car depth
 CH = Car height
 DW = Door width
 DH = Door height
 FD = Floor distance
 COP = Car Operating Panel
 LOP = Landing Operating Panel

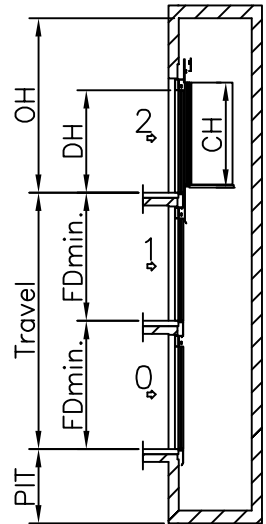
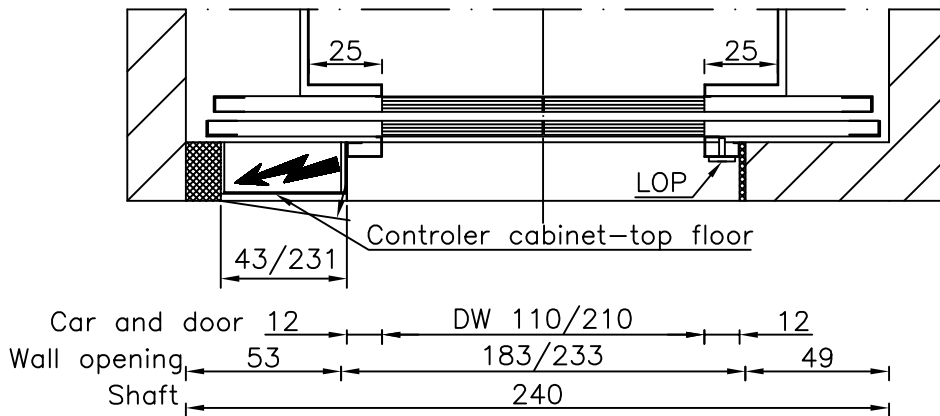
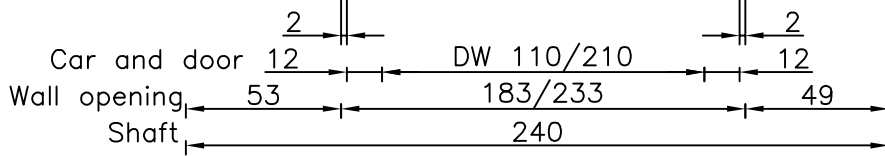

Speed: 1 m/s	PIT: 140 cm
OH: 370 cm	
CW: 160 cm	DW: 110 cm
CD: 140 cm	DH: 210 cm
CH: 220 cm	
FDmin.: 260 (CH+50 cm)	

TYPICAL POWER REQUIREMENTS	
Motor Power (k.W.)	6 kW
Running current	21,7 A
Starting current	30,9 A

Type:	GEARLESS MRL 2:1 1000 kg CT11		Drawn By:	Tomi Irgolič	
			Date:	16.02.2007	
			Revision:	00	
	ELECTRIC		A4	Page: 71	
			1:25		

Dimensions in cm.

