

Microlift Builder's Work and Electrical Details

Stage 1 - Heated Car and Lift Intercom Options

Site: [REDACTED]

Job No: [REDACTED]

Model: Microlift [REDACTED]

Date: [REDACTED]

BUILDING

The following work must be completed **before the lift installation can commence**:

1. Provide a trimmed floor aperture at each floor through which the Microlift is to travel to the dimensions [REDACTED] mm wide x [REDACTED] mm deep (tolerance +25 mm, -0 mm). See brochure

2. Ensure that the base on which the lift is to sit is flat and dry and capable of withstanding a downward deadload of [REDACTED] kg, distributed over four corners of the lift structure. See Data Sheet DS003

IMPORTANT: *In the event of there being an accessible void beneath the base of the lift shaft, suitable precautions must be taken to avoid possible injury to persons, and it is advised that a structural engineer be consulted if such a situation exists. Please contact us to discuss the matter further.*

3. Provide adequate dry storage, adjacent to the lift shaft, for our materials when delivered to site.
4. Ensure that there is safe access to the lift well, eg **stairs** and **boarded floors**, to each level of the building that the lift is to serve to enable us to carry and distribute the heavy equipment in safety.

NOTE: If there is no safe means of access, as outlined above, we shall be unable to install the lift equipment and may need to withdraw our labour from site. Should this situation arise, we would raise a charge, in line with our quotation, and would not return to site until safe to do so.

5. **IMPORTANT:** Do not build any entrance fronts at this stage but leave clear from floor to ceiling until after the lift has been fitted. PLEASE NOTE that if any entrance fronts are constructed at this stage, we will not be able to install the lift until they have been removed.

ELECTRICAL PROVISION required before first fix* - including Heated Car and Lift Intercom Options

NB A lift installation is considered to be a self-contained piece of equipment and as such is not required to conform in all respects with the 16th Edition of the Institute of Electrical Engineers Regulations for Electrical Installations

- 6a Provide a permanent 415 V - 3 phase [REDACTED]/240 V - 1 phase (50 Hertz) power supply with good earth, terminating in a 15 amp triple pole [REDACTED]/single pole and neutral fused and switched isolator, which should be capable of being locked in the **off** position. Motor running current = [REDACTED] amps, starting current = [REDACTED] amps, [REDACTED] kW, [REDACTED] HP. See Data Sheet DS0006

The isolator is to be positioned adjacent to the lift well (**not inside** the lift well) approximately 2 metres (6' 6") above finished floor level at the top floor served.

****If the permanent isolator is not available at this stage and we are unable to route our mains cable prior to the cladding (enclosure) work, builder must arrange to route our mains cable to the isolator position in order to avoid possible problems with final finishes at commission stage.***

In addition, a dedicated 240V – 1-phase – 10 amp supply, terminated in a switched 13 amp socket for the motor compartment light **MUST BE PROVIDED INSIDE** what will be the lift motor compartment at the top of the lift well.

- 6b Provide for the heater a 240V-1 phase-10 amp supply terminated in a switched and fused outlet positioned next to the lift isolator (see above). **(Option – delete if not required)**
- 6c Provide for the intercom a 240V-1 phase-10 amp supply terminated in a switched and fused outlet positioned next to the lift isolator (see above). **(Option – delete if not required)**
7. Provide a 110 V or 240 V power supply for tools, adjacent to the lift for the duration of the installation work.
8. Provide adequate temporary lighting in the lift well for the duration of the installation.

Microlift Builder's Work Schedule

Stage 2

Post Installation

Job No: [REDACTED]

Date: [REDACTED]

After the Microlift has been installed, the builder is to carry out the following work:

Complete the enclosure (lift well) around the Microlift, generally as our attached drawings.

It is **imperative** that the Microlift is enclosed thoroughly and properly to comply with the current safety requirements of the Health & Safety at Work Act, together with the Supply of Machinery (Safety) Regulations 1992.

1. The enclosure may have to comply with the Local Authority Fire Regulations and we recommend you check their requirements. It is typical to provide a fire-resistant enclosure by using battens or spacers fixed to our structure and clad with Supalux. Care must be taken, however, to avoid damage to our cables when fixing any materials to our structure. If any other form of enclosure is used, the builder is to protect the Microlift equipment from dust and damp whilst carrying out the work.
2. Form entrance liners around our shutters at each entrance to exclude any gaps which could become finger traps. **However, please ensure that the cladding does not cover the shutter release mechanism keyhole situated below and to the right of the push button control panel.**
3. Provide two x **hinged and lockable** access doors each 700mm wide x **700mm** high at the top of the lift well for maintenance purposes, as shown on our general arrangement drawing. **If this arrangement cannot be achieved, please contact us to discuss.** Please note that the locking of the access doors must be by means of a simple mortise (Union ref 2177) or cylinder lock (Yale ref P84) and that tower/barrel bolts, budget locks or mirror screws are **not** acceptable, as they do not comply with current regulations.

NOTE: It is now a statutory obligation to provide a safe means of access and lighting to the lift motor room. Thus, we suggest that a safe step ladder or ladder should always be available for safe access to the motor room.

NOTE: Permanent notices reading DANGER - LIFT MACHINERY, UNAUTHORISED ACCESS PROHIBITED - DOOR TO BE KEPT LOCKED must be fitted on the outside of the motor room doors to comply with current safety regulations. Our installer will fit these notices when he returns to test and commission the lift.

4. Thoroughly clean down the interior of the lift shaft and lift equipment to remove all builder's rubble, dust and waste matter. We will not accept liability for any damage caused through negligence or non-compliance with these requirements.

NOTE: If any of the above items 1 to 4 have not been completed, we will be unable to test the lift or affix the CE mark, and an additional return visit charge will then be raised before we can make new arrangements to return.

--

DO NOT SCALE

IF IN DOUBT - ASK

ALL DIMS IN MMS

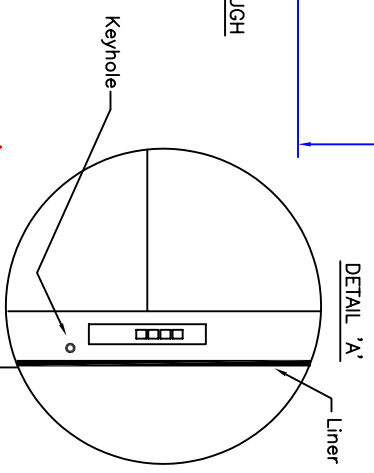
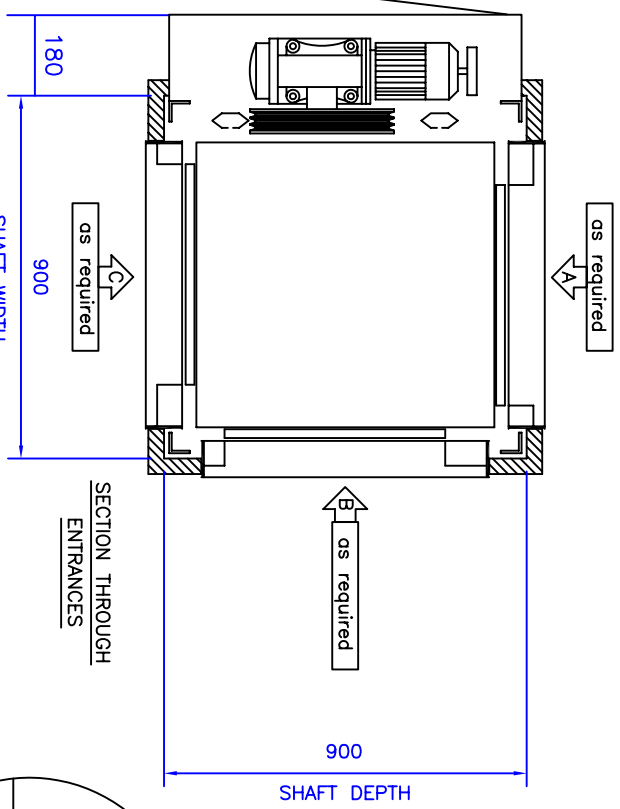
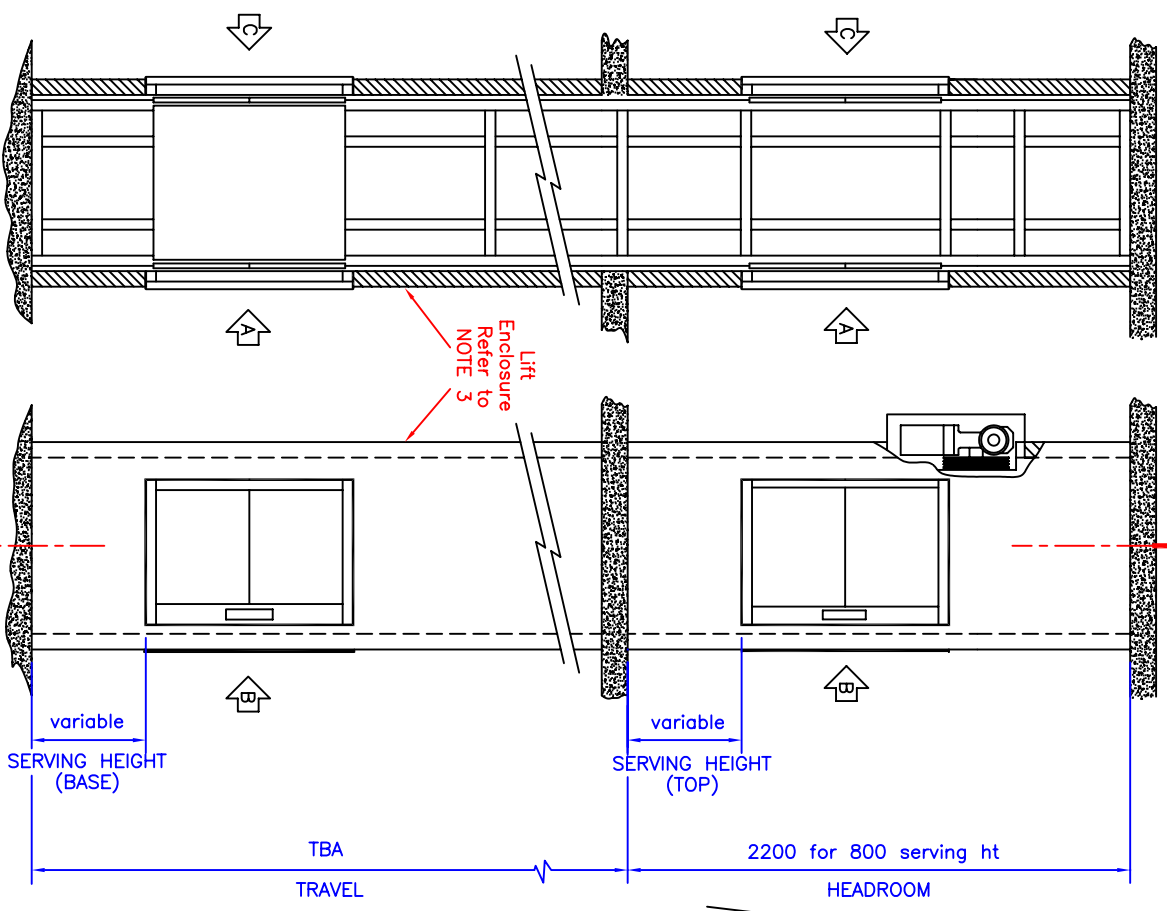

NOTES

1. Please read this drawing in conjunction with our Builder's Work Schedule Stages 1 & 2.
2. Builder to provide floor aperture (lift well) to minimum dimensions width x depth (tolerance +25mm) prior to installation
3. Builder to provide enclosure and entrance liners. Do not obscure shutter/door release keyhole (Detail 'A'). DO NOT BUILD UNTIL AFTER INSTALLATION.
4. Builder to provide lighting within the motor compartment, unless sufficient ambient light is available.

NB If items 3 & 4 (Builder's Work Stage 2) are not complete when we return to test, commission and affix a CE Mark to the lift, then an additional return visit charge will be raised in line with our quotation.

TYPICAL SECTION (X-X)

TYPICAL FRONT ELEVATION IN DIRECTION OF ARROW Z

SITE ADDRESS:

TBA

Microlift
50CLH
 SERVICE LIFTS

DRAWN BY: C.H DATE: 8-9-05

DRAWING NUMBER:

FOR INFO. ONLY